



# ELECTRIC FLEET | LONG-TERM STORAGE

Preparing for long-term storage is a must for your course's golf cars. Below you'll find a program checklist for storing electric-powered Club Cars. For more information on overall golf car maintenance, consult the owner's manual.



## Recommended Vehicle Storage Program

**For the recommended storage method, make sure the vehicles are plugged in and the proper electrolyte level is maintained throughout the entire storage period.** Perform the following procedure at least 2 weeks prior to long-term storage to ensure proper mixing of water and electrolyte. Note that it takes approximately 5 charge cycles with a minimum of 10 EUs removed to properly mix the water with electrolyte. **DO NOT** water batteries immediately prior to storage as this will not allow sufficient charge time to mix the water with the electrolyte. Freezing can occur when batteries are stored in this condition.

**A** **2 weeks prior to storage:** Check the water levels in each battery cell. If water is required, fill the cells to cover the plates, charge the set, and then use distilled water to top off each cell. Electrolyte levels should be from 1/2 inch (13 mm) above plates to 1/4 inch (6 mm) below the level indicator. (See illustration.)

**B** **Immediately prior to storage:**

- Turn the key switch to the OFF position, remove the key, and leave the forward/reverse switch in the NEUTRAL position during storage.
- Power down all accessories including GPS units, fans, etc.
- If Visage or Guardian units are installed on vehicles and remote monitoring through the storage period is desired, skip to step E.
- Place the tow/run switch in the TOW position. Note: Since the battery warning light does not illuminate with the tow switch in TOW, do not use the warning light as an indication of the batteries' charge state.
- Clean the battery packs, tops and terminals using a battery acid neutralizer (1 cup baking soda per 1 gallon water). Check, clean, and treat battery terminal connections with a battery terminal protector spray.
- Tighten all battery cable connections per the owner's manual.
- If your vehicle is equipped with a Single Point Watering System, make sure to place the fill tube on top of the battery. This will allow for any water in the tube to drain back into the batteries.

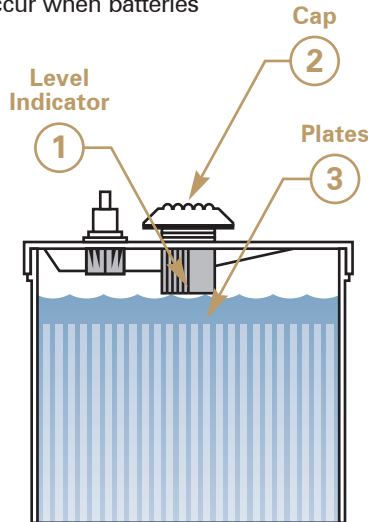

Maintain electrolyte levels from at least 1/2-inch (13 mm) above plates to 1/4-inch (6 mm) below level indicator.

*h. Bag protectors should be stored in the DOWN position to reduce risk of the vinyl in the window panel cracking. Windshields should be stored in the UPRIGHT position.*

- Plug the battery charger into the car. Leave chargers plugged in during storage. If cars are equipped with an onboard computer, the OBC automatically will activate the charger when needed.
- If the battery charger is left plugged in during extended storage, check the electrolyte level and the charger function at least once a month to ensure that proper operation is maintained. To check charger function, disconnect the DC cord (stationary charger) from the vehicle or the AC cord (onboard charger) from the power source and wait five seconds before reconnecting. The charger is functioning properly if the ammeter indicates current.
- If AC power is off for seven or more days, the OBC will not function or charge the vehicle again until it has been restarted. To restart the computer:
  - Ensure AC power has been restored
  - Disconnect the DC cord (stationary charger) from the vehicle or the AC cord (onboard charger) from the power source; wait five seconds and reconnect.
- Check tire pressure and inflate to 18-20 PSI, or as called for in the owner's manual.
- Perform all semi-annual lubrications.
- Thoroughly clean the front and rear body, seats, battery compartment and underside of vehicle.
- Make sure the storage facility has adequate ventilation as called for in the owner's manual.
- Do not engage the park brake, but secure the car from rolling. Chock the wheels of vehicle since the FNR is in NEUTRAL and the vehicle is in TOW position.



# ELECTRIC FLEET | LONG-TERM STORAGE



Preparing for long-term storage is a must for your course's golf cars. Below you'll find a program checklist for storing electric-powered Club Cars. For more information on overall golf car maintenance, consult the owner's manual.

## Alternative Vehicle Storage Program

If any of the following conditions exist, use the alternate storage method.

- The charger cannot remain plugged in continuously throughout the storage period
- AC power will not be available during the storage period
- Electrolyte levels will not be maintained throughout the storage period

Perform the following procedure at least 2 weeks prior to long-term storage to ensure proper mixing of water and electrolyte. Note that it takes approximately 5 charge cycles with a minimum of 10 EUs removed to properly mix the water with electrolyte. **DO NOT** water batteries immediately prior to storage as this will not provide sufficient charge time to mix the water with the electrolyte. Freezing can occur when batteries are stored in this condition.

**A** **2 weeks prior to storage:** Check the water levels in each battery cell. If water is required, fill the cells to cover the plates, charge the set, and then use distilled water to top off each cell. Electrolyte level should be from 1/2 inch (13 mm) above plates to 1/4 inch (6 mm) below the level indicator. (See illustration.)

**B** **Immediately prior to storage:**

- Ensure vehicles are fully charged per the owner's manual.
- Turn the key switch to the OFF position, remove the key, and leave the forward/reverse switch in the NEUTRAL position during storage.
- Place the tow/run switch in the TOW position. Note: Since the battery warning light does not illuminate with the tow switch in TOW, do not use the warning light as an indication of the batteries' charge state.

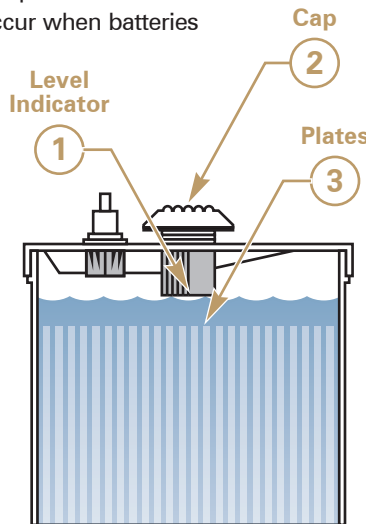

Maintain electrolyte level from at least 1/2-inch (13 mm) above plates to 1/4-inch (6 mm) below level indicator.

- Clean the battery packs, tops and terminals using a battery acid neutralizer (1 cup baking soda per 1 gallon water). Check, clean, and treat battery terminal connections with a battery terminal protector spray.
- If your vehicle is equipped with a Single Point Watering System, make sure to place the fill tube on top of the battery. This will allow for any water in the tube to drain back into the batteries.
- Bag protectors should be stored in the DOWN position to reduce risk of the vinyl in the window panel cracking. Windshields should be stored in the UPRIGHT position.

- Disconnect batteries per the owner's manual ensuring cables do not come into contact with a terminal.
- Check tire pressure and inflate to 18-20 PSI, or as called for in the owner's manual.
- Perform all semiannual lubrications.
- Thoroughly clean the front and rear body, seats, battery compartment and underside of vehicle.
- Make sure the storage facility has adequate ventilation as called for in the owner's manual.
- Do not engage the park brake, but secure the car from rolling. Chock the wheels of vehicle since the FNR is in NEUTRAL and the vehicle is in TOW position.



# GASOLINE FLEET | LONG-TERM STORAGE

Preparing for long-term storage is a must for your course's golf cars. Below you'll find a program checklist for storing gasoline-powered Club Cars. For more information on overall golf car maintenance, consult the owner's manual.



## Recommended Vehicle Storage Program

- A** Place the forward/reverse handle in the **NEUTRAL** position and the neutral lockout cam in the **MAINTENANCE** position.
- B** Turn the fuel shut-off valve to the closed **OFF** position, turn the key switch to **ON** position and run the engine until fuel remaining in the carburetor and fuel lines is depleted and the engine stalls. Turn the key switch to the **OFF** position and remove the key. Return the neutral lockout cam to the **OPERATE** position.
- C** Loosen but do not remove the carburetor drain screw and drain remaining fuel into a clean container. Pour the fuel from the container into the vehicle's fuel tank and tighten the carburetor drain screw.
- D** Disconnect the fuel vent line from the fuel tank vent barb. Use a slip-on vinyl cap to plug the fuel tank vent nipple so it is air tight.
- E** Disconnect the battery cables, starting with the negative cable.
- F** Check tire pressure and inflate to 12-14 PSI, or as called for in the owner's manual.
- G** Perform all semiannual lubrications and make sure engine oil levels meet the owner's manual requirements.
- H** Clean the battery using a battery acid neutralizer (1 cup of baking soda per 1 gallon of water). Check, clean and treat battery terminal connections with a battery terminal protector spray.
- I** Remove the spark plug and pour 1/2 ounce of SAE 10 weight oil into the engine through the spark plug hole. Rotate the engine crankshaft by hand several times and then re-install the spark plug.
- J** Do not engage the park brake, but secure the car from rolling.
- K** Bag protectors should be stored in the **DOWN** position to reduce risk of the vinyl in the window panel cracking. Windshields should be stored in the **UPRIGHT** position.